



atlas

**automated
synthesis system**

Distributed by:

Lab Unlimited
CARL STUART GROUP

Tallaght Business Park
Whitestown, Dublin 24,
Ireland
D24 RFK3

Tel: (01) 4523432
Fax: (01) 4523967

E-mail: info@labunlimited.com
Web: www.labunlimited.com

Quatro House, Frimley Road,
Camberley,
United Kingdom
GU16 7ER

Tel: 08452 30 40 30
Fax: 08452 30 50 30

E-mail: info@labunlimited.co.uk
Web: www.labunlimited.co.uk

Atlas simply does it all

Specifications

- **Scale:** 1ml to 5 litres
- **Control:** Simple control wheel (on Atlas Base) or PC software
- **Temperature range:** Jacketed vessels from -90°C to +250°C, hotplate to +350°C or hot and cold plate from -40°C to +160°C
- **Stirring:** Up to 1200rpm magnetic or 800rpm overhead stirrer (options to 2000rpm)
- **Vessels:** Jacketed vessels (50ml to 5L) in glass or stainless steel, round bottom flasks (50ml to 2L) or vials
- **Sensors:** Temperature, pH, pressure, turbidity, gas flow etc.
- **Reaction calorimetry:** Power Compensation or Heat Flow Calorimetry
- **Pressure:** Jacketed reactors from vacuum to 3 bar or electrically heated systems to 200 bar
- **Reagent addition and sampling:** Automated dosing and sampling of liquids and full gas control
- **Configuration:** Single vessel or parallel reactors

Benefits

- **Easy to use:** Twist and click knob, large display and intuitive
- **Automated:** Walk away synthesis
- **Full data capture:** Data automatically recorded by Atlas Base (downloadable by USB memory stick) or PC software
- **Quick:** Everything clicks together quickly and easily without the need for tools
- **Small footprint:** 23cm (9") square easily fits in fume cupboards
- **Robust:** Specifically designed for use in chemical laboratories
- **Safe:** Auto shutdown, alarms and safe touch surfaces

atlas

Atlas is a revolutionary range of modular products, which can form a wide range of chemical reactors. Atlas offers manual or automated control of one or many reactions at a time with volumes from 1ml to 5 litres in jacketed reactors, flasks or vials.

Atlas applications include synthesis, calorimetry, process optimization, crystallization control, automated addition or pH control, high pressure reactions, parallel chemistry and many more.

Atlas
control
jacketed
chemistry
Full calorimetry use
Hydrogenation
Reactors
data
reactor
Jacketed
Calorimetry
Automatically
PC
Sensors
base
range
systems
Pressure
Synthesis
time
automated
reaction
pH
Round
vessel
stirrer
temperature
gas
parallel
Automated overhead
Potassium manual
Sodium Process
monitoring
reactions





Easy and Flexible Control

The Atlas Base can be configured into a variety of different systems for different applications. Atlas reactor systems can be controlled in 3 ways:

Direct control

Click to select stirrer speed or temperature and then turn the control knob to edit the value. Control reaction temperature using the hotplate or a circulator and stirrer speed using a magnetic or overhead stirrer.



Automated experiments without a PC

Edit and run profiles automatically from the Atlas Base to control set points or ramps for heating, cooling, stirring and reagent addition. Define up to 99 steps, each with a defined time, stirrer speed, temperature and volume of liquid to be added.

PC software

Use full PC software for sophisticated recipe control, real time data plotting and control of other manufacturer's hardware. The parallel software can also control many bases from one PC.



Atlas Jacketed Reactor Features

Height adjustable stirrer seal

Chemically resistant stirrer seal and guide allows easy stirrer height adjustment

Powerful stirring

Compact, auto aligning stirrer up to 800rpm. High torque and high speed options available

Quick connections

Thermo fluid connections made in seconds

Jacketed vessels

50ml, 100ml, 250ml, 500ml, 1L and 2L (3L and 5L with Remote Mount). Range of profiles and vacuum jacket options

Bottom outlet valve

Spring loaded valve offers leak free sealing even at extremes of temperature and pressure

Circulator control

Connect a circulator to enable intelligent temperature control

USB download

Download data to USB stick

Parallel chemistry

Many bases can be controlled by one PC

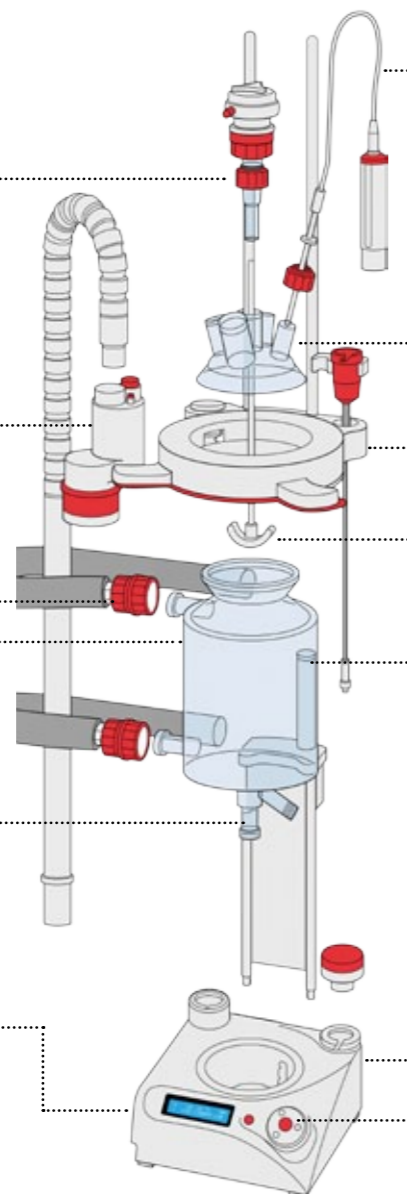

Wide range of sensors

Temperature probes, pH sensors, turbidity probes etc. with localized calibration

7 port lid

A wide range of port sizes in both vertical and compound angle configurations

Quick clamp

No tools required to change jacketed vessels in seconds

Wide range of stirrers

Different styles and lengths available

Oil drain unit

Press button to drain thermo fluid

Syringe pump control

Connect the Atlas Syringe Pump to coordinate control of additions with temperature and stirring

Data logging

All sensor data is logged automatically even without a PC

Simple control

Twist & click knob to change temperature / stirrer speed or edit and run automated experiments

systems

Atlas can be configured into a wide range of different systems.

All of the Atlas Jacketed Reactor Systems are based on the Atlas Potassium System (see next page).

Jacketed vessels from 50ml to 5 litres can be controlled in a fully automated fashion. They can be easily changed due to the quick release vessel clamp, auto-aligning stirrer, quick connect fluid hoses and semi-automatic circulator fluid drain.

For systems using vessels such as round bottom flasks, vials and reactor tubes, Atlas offers the Lithium, Sodium and Orbit systems. For controlled low-temperature applications, Atlas offers the Cryo Reactor systems (see next page).

atlas

automated synthesis system

A selection of popular Atlas systems is shown here. Due to the modular nature of Atlas, many customers choose to combine functionalities e.g. reaction calorimetry with gravimetric dosing and pH sensing or sonocrystallization with volumetric dosing and turbidity sensing.

For further details on the specifications of these systems please visit www.syrris.com or see the Syrris Batch Chemistry Reactors catalogue.



Atlas Potassium
Automate processes from -90°C to +250°C and from vacuum to 0.25 bar in the regular Atlas jacketed reactor system.



Atlas Gravimetric Dosing
Dose a defined mass by controlling a peristaltic pump and balance with the Atlas PC software.

Atlas Volumetric Dosing
Automate volumetric dosing by adding an Atlas Syringe Pump to the Potassium system.



Atlas Calorimeter
Plot power and enthalpy in real time using heat flow or power compensation calorimetry.



Atlas Sodium Pressure
Control reactions up to 200 bar and 320°C with volumes up to 450ml in metal reactors.

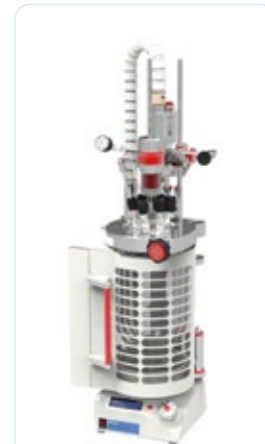

Atlas Potassium Pressure
Control reactions up to 3 bar and 200°C with volumes up to 3L in a glass jacketed reactor.



Atlas Parallel
Automate up to 4 systems in parallel from one PC using the Atlas Parallel software.



Atlas Remote Mount
Locate vessels up to 5L away from the Atlas Base.



Atlas pH Control
Control and log pH by connecting the Atlas pH probe and Atlas Syringe Pump.



Atlas Turbidity
Display and log turbidity by connecting the Atlas Turbidity Probe to the base.



Atlas Sonolab
Use ultrasound energy in crystallizations for narrow particle size distribution and polymorph control.



Orbit
Perform 6 (45ml) or 12 (10ml) reactions in parallel with reflux under an inert gas blanket.



Atlas Lithium
Automate temperature control and magnetic stirring in round bottom flasks from 50ml to 2L.



Atlas Sodium
Automate temperature control and overhead stirring in round bottom flasks from 50ml to 2L.



Atlas Cryo Reactor
Cool reactions to process temperatures as low as -80°C with volumes up to 500ml.

applications

Atlas systems are used in hundreds of laboratories around the world in sectors such as the pharmaceutical industry, CROs, academia, petrochemical industry, fine chemical synthesis, nanoparticle synthesis and many more.

Applications include:

- **Synthesis in Jacketed Reactors:**
Synthesis of APIs, fine chemicals, nanoparticles, etc.
- **Synthesis in automated Jacketed Reactors:**
Process development, process optimization, design of experiment, etc.
- **Calorimetry:**
Kinetic studies, scale-up, process safety, end point detection, etc.
- **Crystallization:**
Controlled API crystallization, purification, polymorph control, API formulation, etc.
- **Pressure reactions:**
Polymer synthesis, hydrogenation, carbonylation, etc.
- **Synthesis in flasks, tubes and vials:**
Process optimization, discovery, medicinal chemistry, etc.

Synthesis in Jacketed Reactors

Atlas simply does it all

Atlas is the most flexible and easy to use jacketed reactor system available, enabling reactions from -90°C to +250°C. The design saves space and money by allowing 50ml, 100ml, 250ml, 500ml, 1L, 2L, 3L and 5L jacketed vessels to be used with same clamp, lid and circulator.

Systems can be set-up easily as no tools are required. Vessels and stirrers can be changed quickly due to the jacket oil drain system, quick vessel clamp, clip on/off auto-aligning stirrer motor and easy adjust stirrer seal and guide. Choose from a wide range of vessel profiles, jacket options, stirrers, sensors and accessories.



The Atlas Base intelligently controls circulators (e.g. Julabo, Huber, etc.) based on in-reaction temperature probes. Sensors such as temperature, pH, turbidity etc. can be plugged into the base. Data is displayed on the base, automatically logged and can be downloaded as one csv file to a USB stick.

Systems can either be manually controlled, automatically controlled by the Atlas Base or fully automated using the Atlas PC Software. Atlas' modularity allows control of single or parallel jacketed automated reactors.

Automated Synthesis

Atlas can perform automated experiments with or without a PC. Using the front panel controls, set points, ramps or profiles can be set for reaction temperature, stirrer speed and reagent additions. The Atlas PC Software uses a “drag and drop” interface to allow the easy set-up and control of demanding experiments.

Atlas PC Software

Atlas PC Software offers advanced functionality to all Atlas systems. Atlas and other manufacturer's apparatus can be controlled in sophisticated recipes with real time graphs, alarms and shutdowns. The flexible software allows experiments to be performed in three simple steps: 1. Define apparatus, 2. Create recipe, 3. Run experiment.

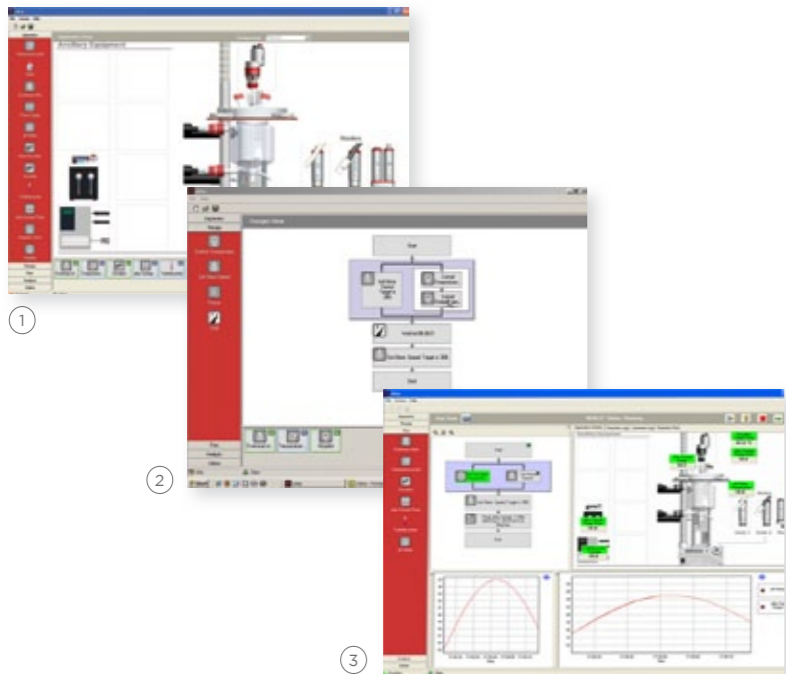

Atlas profiles

Without a PC, Atlas can automatically control experiments with up to 99 steps. The Atlas Base controls reaction temperature, overhead stirrer speed and reagent addition from a pump.

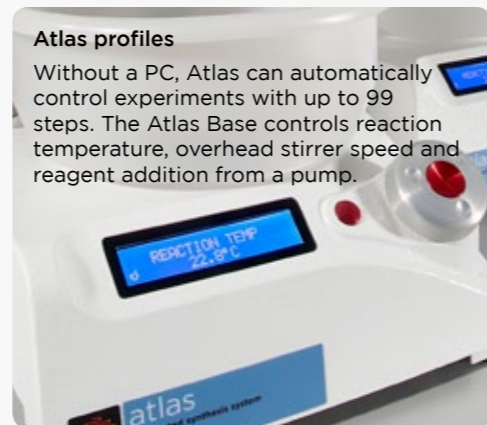

Atlas Port

Atlas Ports offer the ability to automate 3rd party devices such as pumps, balances, sensors, etc. with an Atlas system.

Reagent Addition and Sampling

The Atlas Syringe Pumps (regular up to 20ml/min or XL up to 200ml/min) are versatile dosing and sampling systems. They allow 2 independent refilling flows, one continuous flow, reaction sampling, intelligent control of pH and temperature dependent dosing.

Intelligent independent control

During reagent additions, Atlas Syringe Pumps (shown below) can monitor reaction temperature and pause in the case of an exotherm. By connecting a pH meter, they can monitor and automatically control the pH of a reaction by adding an acid and/or base.

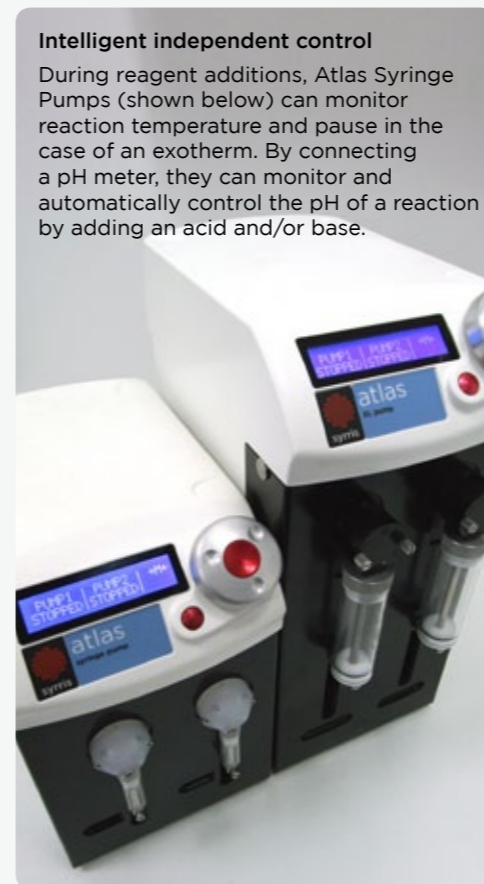

Excellent chemical resistance

The wetted parts are made from glass, PTFE and PCTFE allowing the widest range of reagents to be used.



Autosampling

Using the Atlas Autosampler and probe, samples can automatically be aspirated into HPLC vials at defined intervals. Dose with one syringe while sampling with the other.



3 ways to control

The Atlas Syringe Pumps can be controlled in standalone mode using the front panel to perform automated processes. Alternatively, they can be connected to an Atlas Base or the Atlas PC Software for sophisticated control.



Calorimetry

The Atlas Calorimeter accurately measures the power and enthalpy of chemical reactions. This provides reaction kinetics and safety data that is invaluable in process optimization, scale-up and hazard evaluation studies. The Atlas Calorimeter is extremely accurate, easy to use and automatically compensates for changes in UA and the heat of addition.

Heat Flow Calorimetry and Power Compensation Calorimetry

The Atlas Calorimeter has been designed so heat flow calorimetry (HFC) and power compensation calorimetry (PCC) are performed with the same equipment, allowing a choice of methods for the reaction.

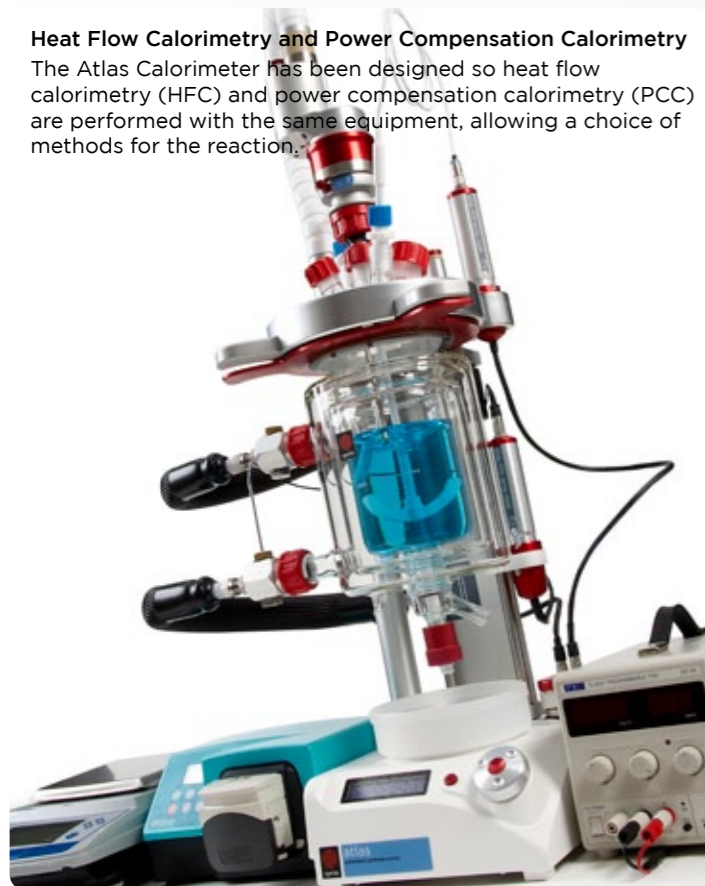

Easy to use calorimetry software

The Atlas Calorimeter is designed for ease of use. Setting up a system, defining and running an experiment, then analyzing the data are all made easy with the Atlas Calorimeter.



Crystallization

Atlas has a range of systems for both crystallization monitoring and control. These offer reproducible control of nucleation, particle size, polymorph selectivity and narrow particle size distribution.

Atlas Sonolab

Using Prosonix ultrasound technology, the Sonolab allows repeatable control of nucleation. This allows narrow particle size distribution and control of particle size, shape, crystallinity and polymorphism.



Sonomilling

The Atlas Sonolab can be used for ultrasonic wet milling. This offers a scalable technique to access smaller particles with a narrower size distribution.

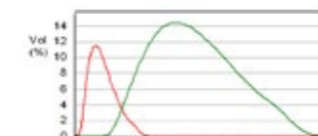

Paracetamol particle size distribution, with (red) and without (green) ultrasonic wet milling.

Particle analysis

Atlas allows integration of particle analysis instruments e.g. Particle Visualization and FBRM (Focussed Beam Reflectance Measurement) devices to monitor particle size in real time.

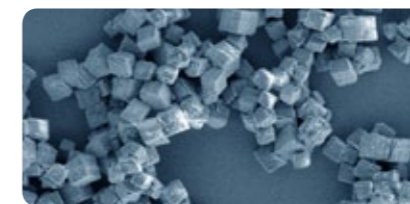

Turbidity Probe

The Atlas Turbidity Probe can be used to monitor crystallization processes with or without a PC. The Atlas PC Software allows it to be used as a control parameter.



Pressure Reactors

For pressure reactions such as hydrogenations, polymerizations, etc. or vacuum applications, Atlas offers two types of pressure vessel: 3 bar jacketed reactors and 200 bar electrically heated reactors. For gas control, options include the Gas Selection Module, Pressure Control Module and mass flow meters or controllers.

3 Bar Atlas Potassium

Easy to use reactor for applications where pressures up to 3 bar and temperatures from -80°C to $+200^{\circ}\text{C}$ are required. Available in vessels sizes from 100ml to 3L, with or without vacuum jacket.



Gas Selection Module

The Gas Selection Module allows 3 gases to be permanently connected to the module yet only one gas connected to the reactor at any one time.



Pressure Control Module

This module automatically controls the dosing of gas into the reactor. Commands include control pressure, purge and vent.



200 Bar Atlas Sodium

Ideal for applications where pressures up to 200 bar and reaction temperatures up to 320°C are required. Available in stainless steel 316, hastelloy and titanium and in vessel sizes from 100ml to 450ml.



Round Bottom Flasks and Vials

The Atlas Lithium, Cryo Reactor, Sodium and Orbit systems automate reactions in round bottom flasks vials or reaction tubes. The Atlas Hotplate and Stacking Dry Bath rapidly heat round bottom flasks of 50ml, 100ml, 250ml, 500ml and 1L up to 280°C . A wide range of automation options exist including pumps, PC software and a range of sensors.

Orbit

Orbit allows 6 or 12 reaction tubes to be magnetically stirred in an inert atmosphere and be heated to 280°C with reflux or cooled to -40°C .

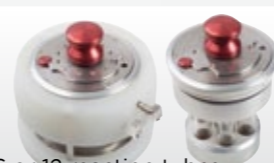

Dry Baths

The Stacking Dry Bath has concentric inserts to hold flasks from 50ml to 1 litre. The exterior surface always remains safe to touch. Option for 2 litre.



Hot and Cold Plate

The Atlas Hot and Cold Plate provides cooling from -40°C and heating to 160°C for reactions in flasks or vials.



Atlas Cryo Reactor

The Atlas Cryo Reactor is used to cool reactions to -80°C in a rapid and controlled manner. The system accommodates reaction volumes of 50ml, 100ml, 250ml and 500ml.



Atlas Lithium

With the Atlas Magnetic Stirrer, Hotplate and Dry Baths, Lithium can automatically heat and stir up to 3 flasks or up to 12 parallel vials.



Atlas Sodium

Atlas Sodium is an automated reactor system for round bottom flasks with overhead stirring for viscous or heterogeneous reactions (to 800rpm).



Atlas is designed and manufactured by Syrris, the world's most advanced provider of laboratory scale chemistry systems.

Syrris' network of offices in the UK, USA, Japan, India and Brazil plus over 35 distributors worldwide offer local service and support.



Distributed by:

Lab Unlimited
CARL STUART GROUP

Tallaght Business Park
Whitestown, Dublin 24,
Ireland
D24 RFK3

Tel: (01) 4523432
Fax: (01) 4523967
E-mail: info@labunlimited.com
Web: www.labunlimited.com

Quatro House, Frimley Road,
Camberley,
United Kingdom
GU16 7ER

Tel: 08452 30 40 30
Fax: 08452 30 50 30
E-mail: info@labunlimited.co.uk
Web: www.labunlimited.co.uk